



Film Capacitors - Power Factor Correction

Capacitor Contactors

Series/Type: B44066S
Ordering code: B44066S....C242
Date: 2020-10-20
Version: 1

Characteristics

- Excellent damping of inrush current
- Improved power quality (e.g. avoidance of voltage sags)
- Soft switching of capacitor and thus longer useful life
- Enhanced mean life expectancy
- Reduced ohmic losses
- Easy access for cable connection
- AC6b utilization category for switching 3-phase capacitor

Features

Resistors	Protected with PTFE covering
Leading contacts	With wiper function
Aux-contacts	For all types
Usage	In applications with or without reactors

Technical data and ordering codes

Ordering code	Frequency Hz	Capacitor power at 55 °C 220 ... 240 V kvar	Capacitor power at 55 °C 400 ... 440 V kvar	Capacitor power at 55 °C 660 ... 690 V kvar	Max. current AC6b at 50/60 Hz, 50 °C A
B44066S0711C242	50/60	0 ... 4	0 ... 7.5	0 ... 9	8
B44066S1011C242	50/60	0 ... 5.5	0 ... 10	0 ... 12.5	14
B44066S1211C242	50/60	0 ... 6.7	0 ... 12.5	0 ... 18	18
B44066S1611C242	50/60	0 ... 8.5	0 ... 16.7	0 ... 24	24
B44066S2011C242	50/60	0 ... 10	0 ... 20	0 ... 30	29
B44066S2511C242	50/60	0 ... 15	0 ... 25	0 ... 36	36
B44066S3312C242	50/60	0 ... 20	0 ... 33.3	0 ... 48	48
B44066S4012C242	50/60	0 ... 25	0 ... 40	0 ... 58	58
B44066S5012C242	50/60	0 ... 27	0 ... 50	0 ... 62	70
B44066S6012C242	50/60	0 ... 40	0 ... 60	0 ... 92	92
B44066S7512C242	50/60	0 ... 45	0 ... 75	0 ... 120	108
B44066S8012C241	50	0 ... 48	0 ... 80	0 ... 100	116 *)
B44066S9912C241	50	0 ... 60	0 ... 100	0 ... 143	144 *)

UL listing for 5012, 7512, 8012 & 9912 are not available.

CE marking for 8012 & 9912 are not available.

*) Represents coil available at only 50 Hz. Universal coil 50/60 Hz is not available as of now.

Type/ main contacts		...0711...	...1011...	...1211	...1611...	...2011...	...2511...	...3312...	...4012...	...6012...
Capacitor power at 55 °C ■ 220 ... 240 V ■ 400 ... 440 V ■ 660 ... 690 V	kvar	0 ... 4 0 ... 7.5 0 ... 9	0 ... 5.5 0 ... 10 0 ... 12.5	0 ... 6.7 0 ... 12.5 0 ... 18	0 ... 8.5 0 ... 16.7 0 ... 24	0 ... 10 0 ... 20 0 ... 30	0 ... 15 0 ... 25 0 ... 36	0 ... 20 0 ... 33.3 0 ... 48	0 ... 25 0 ... 40 0 ... 58	0 ... 40 0 ... 60 0 ... 92
Max. current AC6b at 50/60 Hz ■ 50 °C	A	8	14	18	24	29	36	48	58	92
Coil voltage at 50/60 Hz	VAC	204...264	204...264	204...264	204...264	204...264	204...264	204...264	204...264	204...264
Inrush/sealed VA of contactor at max. rated capacitor current	VA	70/8	70/8	70/8	70/8	100/8.5	100/8.5	245/26	245/26	245/26
Rated insulation voltage	VAC	690 ¹⁾	690 ¹⁾	690 ¹⁾	690 ¹⁾	690 ¹⁾	690 ¹⁾	690 ¹⁾	690 ¹⁾	690 ¹⁾
Max. frequency of operations	1/h	240	240	240	240	240	240	240	100	100
Contact life	Million operations	0.2	0.2	0.2	0.2	0.1	0.1	0.1	0.1	0.1
Cable cross section ■ Flexible with cable end sleeve – 1 conductor ■ Flexible with cable end sleeve – 2 conductors	mm ²	2.5 1.5	2.5 1.5	2.5 1.5	4 2.5	4 4	6 4	16 6	16 6	50 25
■ Solid without cable end sleeve – 1 conductor ■ Solid without cable end sleeve – 2 conductors	mm ² (max.)	4 4	4 4	4 4	6 6	10 6	16 10	25 16	25 16	50 35
Weight Type ...C...	kg	0.43	0.43	0.43	0.45	0.60	0.63	1.3	1.3	1.65

1) Applies to networks with grounded star point, over voltage category I to IV, pollution severity 3 (industrial standard).

V_{imp} = 8 kV. Values for other conditions are available upon request.

Type/ auxiliary contacts		...0711...	...1011...	...1211...	...1611...	...2011...	...2511...	...3312...	...4012...	...6012...
Normal Open (NO)		1	1	1	1	1	1	1	1	1
Normal Closed (NC)		1	1	1	1	1	1	2	2	2
Rated insulation voltage	VAC	690 ²⁾	690 ²⁾	690 ²⁾	690 ²⁾	690 ²⁾	690 ²⁾	690 ²⁾	690 ²⁾	690 ²⁾
Rated operational current, utilization category AC15 ■ 220 ... 240 V ■ 380 ... 400 V ■ 440 V	A	2.09	2.09	2.09	2.09	2.09	2.09	2.09	2.09	2.09
	A	1.25	1.25	1.25	1.25	1.25	1.25	1.25	1.25	1.25
	A	1.14	1.14	1.14	1.14	1.14	1.14	1.14	1.14	1.14
Thermal rated current at ambient temperature ■ 40 °C ■ 60 °C	A	10	10	10	10	10	10	10	10	10
	A	8	8	8	8	8	8	8	8	8
Short circuit protection: Max. fuse size, slow, gL (gG)	A	10	10	10	10	10	10	10	10	10

2) Applies to networks with grounded star point, over voltage category I to IV, pollution severity 3 (industrial standard).

$V_{imp} = 8$ kV. Values for other conditions are available upon request.

*) Represents coil available at only 50 Hz. Universal coil 50/60 Hz is not available as of now.

Type/ main contacts		...5012...	...7512...	...8012	...9912...
Capacitor power at 55 °C ■ 220 ... 240 V ■ 400 ... 440 V ■ 660 ... 690 V	kvar	0 ... 27 0 ... 50 0 ... 62	0 ... 45 0 ... 75 0 ... 120	0 ... 48 0 ... 80 0 ... 100	0 ... 60 0 ... 100 0 ... 143
Max. current AC6b at 50/60 Hz ■ 50 °C	A	70	108	116	144
Coil voltage at 50/60 Hz	VAC	204...264	204...264	204...264*)	204...264*)
Inrush/sealed VA of contactor at max. rated capacitor current	VA	245/26	245/26	350/28	350/28
Rated insulation voltage	VAC	690 ¹⁾	690 ¹⁾	690 ¹⁾	690 ¹⁾
Max. frequency of operations	1/h	100	100	100	100
Contact life	Million operations	0.1	0.1	0.1	0.1
Cable cross section ■ Flexible with cable end sleeve – 1 conductor	mm ²	16	50	50	50
■ Flexible with cable end sleeve – 2 conductors		6	25	25	25
■ Solid without cable end sleeve – 1 conductor	mm ² (max.)	25	50	50	50
■ Solid without cable end sleeve – 2 conductors		16	35	35	35
Weight: Type ...C...	kg	1.65	1.65	2.58	2.58

1) Applies to networks with grounded star point, over voltage category I to IV, pollution severity 3 (industrial standard).

$V_{imp} = 8$ kV. Values for other conditions are available upon request.

*) Represents coil available at only 50 Hz.

UL listing for 5012, 7512, 8012 & 9912 are not available.

CE marking for 8012 & 9912 are not available.

Type/ auxiliary contacts		...5012...	...7512...	...8012	...9912...
Normal Open (NO)		1	1	1	1
Normal Closed (NC)		2	2	2	2
Rated insulation voltage	VAC	690 ²⁾	690 ²⁾	690 ²⁾	690 ²⁾
Rated operational current, utilization category AC15					
■ 220 ... 240 V	A	2.09	2.09	2.09	2.09
■ 380 ... 400 V	A	1.25	1.25	1.25	1.25
■ 440 V	A	1.14	1.14	1.14	1.14
Thermal rated current at ambient temperature					
■ 40 °C	A	10	10	10	10
■ 60 °C	A	8	8	8	8
Short circuit protection: Max. fuse size, slow, gL (gG)	A	10	10	10	10

2) Applies to networks with grounded star point, over voltage category I to IV, pollution severity 3 (industrial standard).

$V_{imp} = 8$ kV. Values for other conditions are available on request.

UL listing for 5012, 7512, 8012 & 9912 are not available.

CE marking for 8012 & 9912 are not available.

Connection diagram for all types B44066S...1C242

0711..., 1011..., 1211..., 1611..., 2011..., 2511...

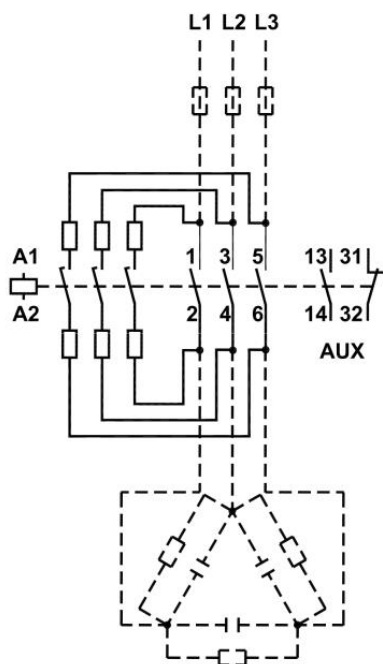

Connection diagram for all types B44066S...2C241 / C242

...3312..., 4012..., 5012..., 6012..., 7512..., 8012..., 9912...

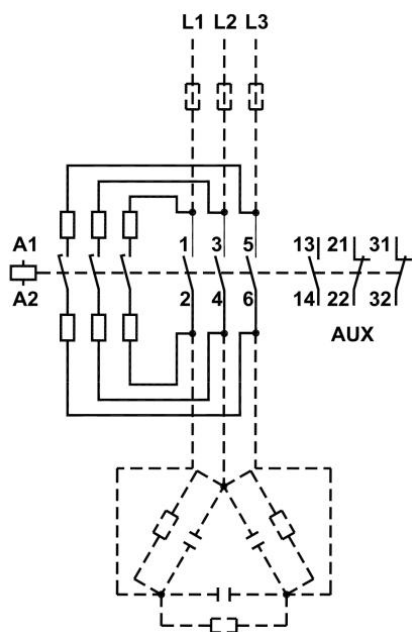

Dimensional drawing

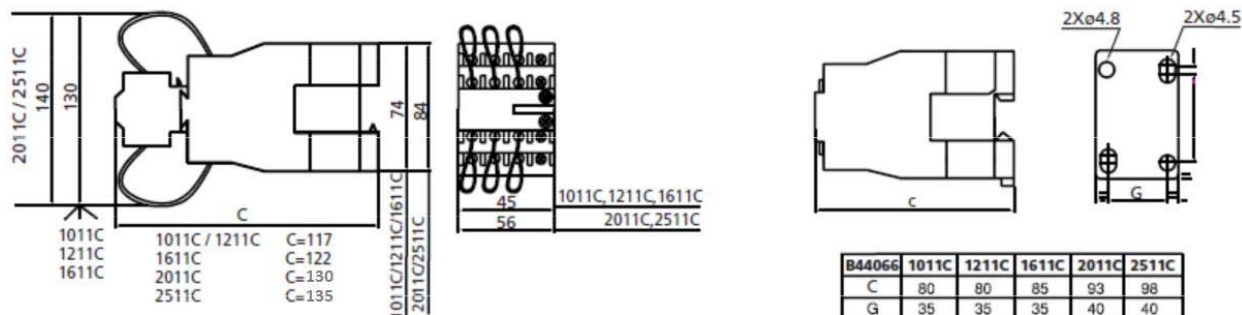
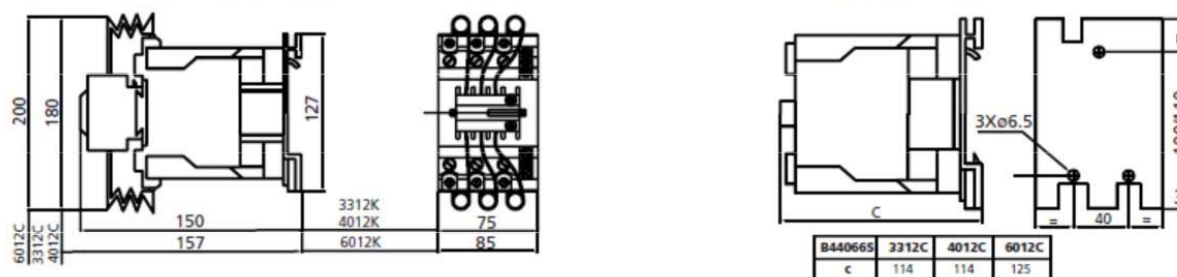
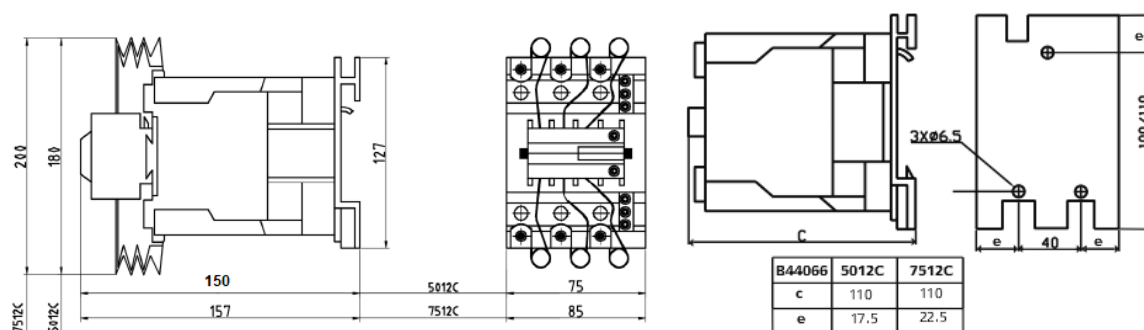
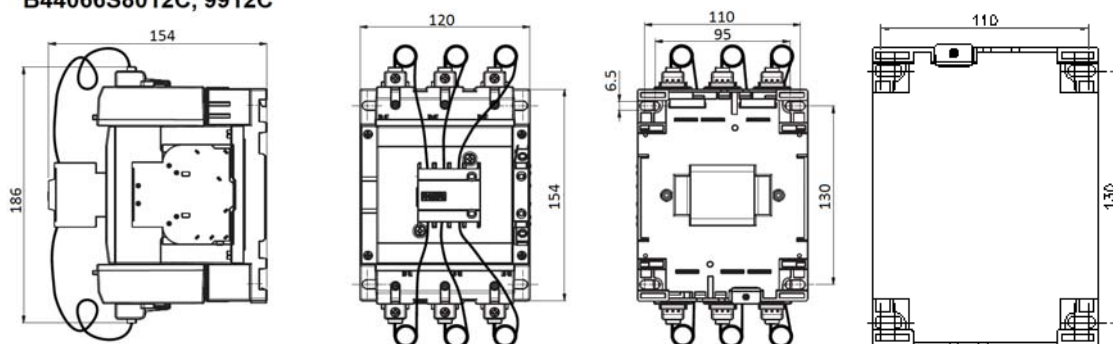
B44066S3312C, 4012C, 6012C

B44066S5012C, 7512C

B44066S8012C, 9912C

Cautions and warnings

In case auxiliary contacts are used for switching of discharge resistors (not in accordance with IEC 60831 standard), make sure that the current of the discharge resistors is not higher than the rated current of the auxiliary contacts.

Mounting instructions

No inflammable material or material sensitive to heat must be close-by the capacitor switching contactors because temperatures may increase around the resistance spirals.

Important notes

The following applies to all products named in this publication:

1. Some parts of this publication contain **statements about the suitability of our products for certain areas of application**. These statements are based on our knowledge of typical requirements that are often placed on our products in the areas of application concerned. We nevertheless expressly point out **that such statements cannot be regarded as binding statements about the suitability of our products for a particular customer application**. As a rule we are either unfamiliar with individual customer applications or less familiar with them than the customers themselves. For these reasons, it is always ultimately incumbent on the customer to check and decide whether a product with the properties described in the product specification is suitable for use in a particular customer application.
2. We also point out that **in individual cases, a malfunction of electronic components or failure before the end of their usual service life cannot be completely ruled out in the current state of the art, even if they are operated as specified**. In customer applications requiring a very high level of operational safety and especially in customer applications in which the malfunction or failure of an electronic component could endanger human life or health (e.g. in accident prevention or life-saving systems), it must therefore be ensured by means of suitable design of the customer application or other action taken by the customer (e.g. installation of protective circuitry or redundancy) that no injury or damage is sustained by third parties in the event of malfunction or failure of an electronic component.
3. **The warnings, cautions and product-specific notes must be observed.**
4. In order to satisfy certain technical requirements, **some of the products described in this publication may contain substances subject to restrictions in certain jurisdictions (e.g. because they are classed as hazardous)**. Useful information on this will be found in our Material Data Sheets on the Internet (www.tdk-electronics.tdk.com/material). Should you have any more detailed questions, please contact our sales offices.
5. We constantly strive to improve our products. Consequently, **the products described in this publication may change from time to time**. The same is true of the corresponding product specifications. Please check therefore to what extent product descriptions and specifications contained in this publication are still applicable before or when you place an order.

We also **reserve the right to discontinue production and delivery of products**. Consequently, we cannot guarantee that all products named in this publication will always be available. The aforementioned does not apply in the case of individual agreements deviating from the foregoing for customer-specific products.

6. Unless otherwise agreed in individual contracts, **all orders are subject to our General Terms and Conditions of Supply**.
7. **Our manufacturing sites serving the automotive business apply the IATF 16949 standard**. The IATF certifications confirm our compliance with requirements regarding the quality management system in the automotive industry. Referring to customer requirements and customer specific requirements ("CSR") TDK always has and will continue to have the policy of respecting individual agreements. Even if IATF 16949 may appear to support the acceptance of unilateral requirements, we hereby like to emphasize that **only requirements mutually agreed upon can and will be implemented in our Quality Management System**. For clarification purposes we like to point out that obligations from IATF 16949 shall only become legally binding if individually agreed upon.

Important notes

8. The trade names EPCOS, CarXield, CeraCharge, CeraDiode, CeraLink, CeraPad, CeraPlas, CSMP, CTVS, DeltaCap, DigiSiMic, ExoCore, FilterCap, FormFit, LeaXield, MiniBlue, MiniCell, MKD, MKK, ModCap, MotorCap, PCC, PhaseCap, PhaseCube, PhaseMod, PhiCap, PowerHap, PQSine, PQvar, SIFERRIT, SIFI, SIKOREL, SilverCap, SIMDAD, SiMic, SIMID, SineFormer, SIOV, ThermoFuse, WindCap, XieldCap are **trademarks registered or pending** in Europe and in other countries. Further information will be found on the Internet at www.tdk-electronics.tdk.com/trademarks.

Release 2020-06